

An Invitation to Sponsor & Exhibit. . .

Florida Academy of Pain Medicine

2007 Annual Meeting

July 27-29, 2007

and meeting in conjunction with FAPM:

Florida Society of Interventional Pain Physicians

The Gaylord Palms Resort

& Convention Center

Kissimmee (Orlando), Florida

How you BENEFIT:

- Meet with pain management practitioners from throughout Florida
- Support the professionals that support your business
- Enjoy 4 indoor acres of the spirit, adventure, and excitement of a grand tour through the Sunshine State.



General Meeting Information

The FAPM Annual Meeting is the largest gathering of pain management physicians in Florida, and it grows every year. Represented specialties include anesthesiology, neurology, neurosurgery, physical medicine and rehabilitation, and others. The exhibit hall sells out every year, so do not delay reserving your placement.

The FAPM staff welcomes the opportunity to create sponsorship packages that meet your individual needs and we are committed to making this conference a success for each vendor! We look forward to seeing you at the Gaylord Palms Resort & Convention Center.

Hotel Reservations: Call 407-586-0000, tell them you are with the Florida Academy of Pain Medicine.
Room Rate: \$199.

Exhibit Hours*:

Friday, July 27, 2007

Move-In: Late afternoon/evening
(Exact times will be available at a later date.)

Saturday, July 28, 2007

Exhibits Open:	7am—7 pm
Specific Events:	
Hot Pick-Up Breakfast	7-8 am
Coffee Break	10-10:30 am
Beverage Break	3-3:30 pm
Reception	5-6:30 pm

*Times may change slightly from this schedule. If that happens, you will be notified.

Sunday, July 29, 2007

Exhibits Open:	7:30-11:00 am
Specific Events:	
Continental Breakfast	7:30-8 am
Coffee Break	10-10:30 am
Move out	11 am

Exhibit Fees**

Priority Booth	\$1250.00
Standard Booth	\$ 950.00

**Please review the enclosed floor plan and indicate your booth preference on the exhibitor contract.

Exhibit Description

Booth packages include 1 8x10' pipe-and-drape booth, 1 6' draped table, 1 chair, 1 wastebasket and 1 identification sign.

Priority Booths are #s 108, 109, 200-209, 300, 302, 303, 400, 404, 406. These are front line booths, corner booths, and booths that have the advantage of being where the food and beverage will be placed.

Questions?

Lorry S. Davis, M.Ed.
FAPM Executive Director
Phone: 904 270 8886
Fax: 904 246 9233
Email: Lorry4@earthlink.net

FAPM Tax ID#: 59-3298602

Commercial Support Opportunities

General Commercial Support Grants

Providing general commercial support for the Meeting offers your company additional exposure at a variety of levels:

Gold - \$5,000

Includes:

- 1 priority exhibit booth
- Recognition in event publicity.
- Listing with logo on FAPM & FSIPP websites
- Special signage in exhibit hall

Silver - \$3,500

Includes:

- 1 standard exhibit booth
- Recognition in event publicity
- Listing with logo on FAPM & FSIPP websites
- Special signage in exhibit hall

Tote Bags

To be negotiated with FAPM.
FAPM's Logo & Conference dates on one side, your logo on the other.

All sponsors and exhibitors will be listed with logos on FAPM & FSIPP websites:

(<http://fapmmed.net>)

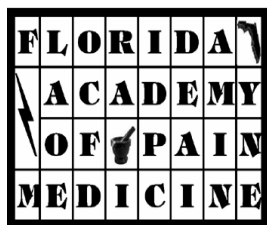

Specific Commercial Support

Commercial support options are also available for specific events during the Meeting:

Saturday FAPM Luncheon - \$5,000

Includes:

- 15 minute presentation to physicians during lunch
- Recognition in event publicity
- Listing with logo on FAPM & FSIPP websites
- 6' draped exhibit table for handouts in the luncheon room
- Special Signage at event
- 2 tickets to event
- 75-100 Physicians

(There are 2 of these sponsorships available, OR consider a \$10,000 sponsorship and owning the entire half hour presentation time.)

Saturday FSIPP Dinner - \$5,000

Includes:

- 15 minute presentation to physicians during dinner
- 100 physicians
- 2 tickets to event
- Recognition in event publicity
- Listing with logo on FAPM & FSIPP websites
- 6' draped table for handouts at the dinner.
- Special Signage at event

Annual Website Sponsorship \$5,000

Includes:

- 1 priority exhibit booth
- Your logo & link on FAPM's Website Home page
- Recognition in event publicity.
- Listing with logo on FAPM & FSIPP websites
- Special Signage at event

Florida Academy of Pain Medicine

P.O. Box 330298 Atlantic Beach, FL 32233-0298 Ph: 904-270-8886 Fax: 904-246-9233
Email: Lorry4@earthlink.net

2007 Annual Meeting July 27-29, 2007

The Gaylord Palms Resort & Convention Center *Kissimmee (Orlando), Florida* **Commercial Support Opportunities**

Increase your company's exposure at the Annual Meeting by providing commercial support.

Commercial support opportunities are listed below. Refer to the sponsor & exhibitor prospectus for complete details on each support level or event. Please check the box next to your commercial support commitment: Commercial support is offered on a first come, first served basis. Complete the information below and return with payment to FAPM.

Company _____
(please print exactly as name should appear in program and on signage.)

- | | | | |
|--|----------------|---|---------|
| <input type="checkbox"/> Gold | \$5,000 | <input type="checkbox"/> Saturday FAPM Luncheon | \$5,000 |
| <input type="checkbox"/> Silver | \$3,500 | <input type="checkbox"/> Saturday FSIPP Dinner | \$5,000 |
| <input type="checkbox"/> Tote Bags | Negotiated | <input type="checkbox"/> Saturday FSIPP Dinner | \$5,000 |

Representative #1 _____ Representative #2 _____

(Sending more than 2 representatives is discouraged and will result in an additional fee of \$250/representative over the limit of 2.)

Address _____

City _____ State _____ Zip _____

Phone _____ FAX _____

E-mail Address _____ @ _____

Total Commercial Support Commitment \$ _____

Method of Payment: Check (Payable to **FAPM**) Visa MasterCard

Card# _____ Exp. Date _____

Name on Card _____ Signature _____

Return this form with payment to:
P.O. Box 330298 Atlantic Beach, FL 32233-0298
Ph: 904-270-8886 Fax: 904-246-9233 Email: Lorry4@earthlink.net
Please call 904-270-8886 with any questions regarding commercial support
Tax ID#: 59-3298602

Floor Plan

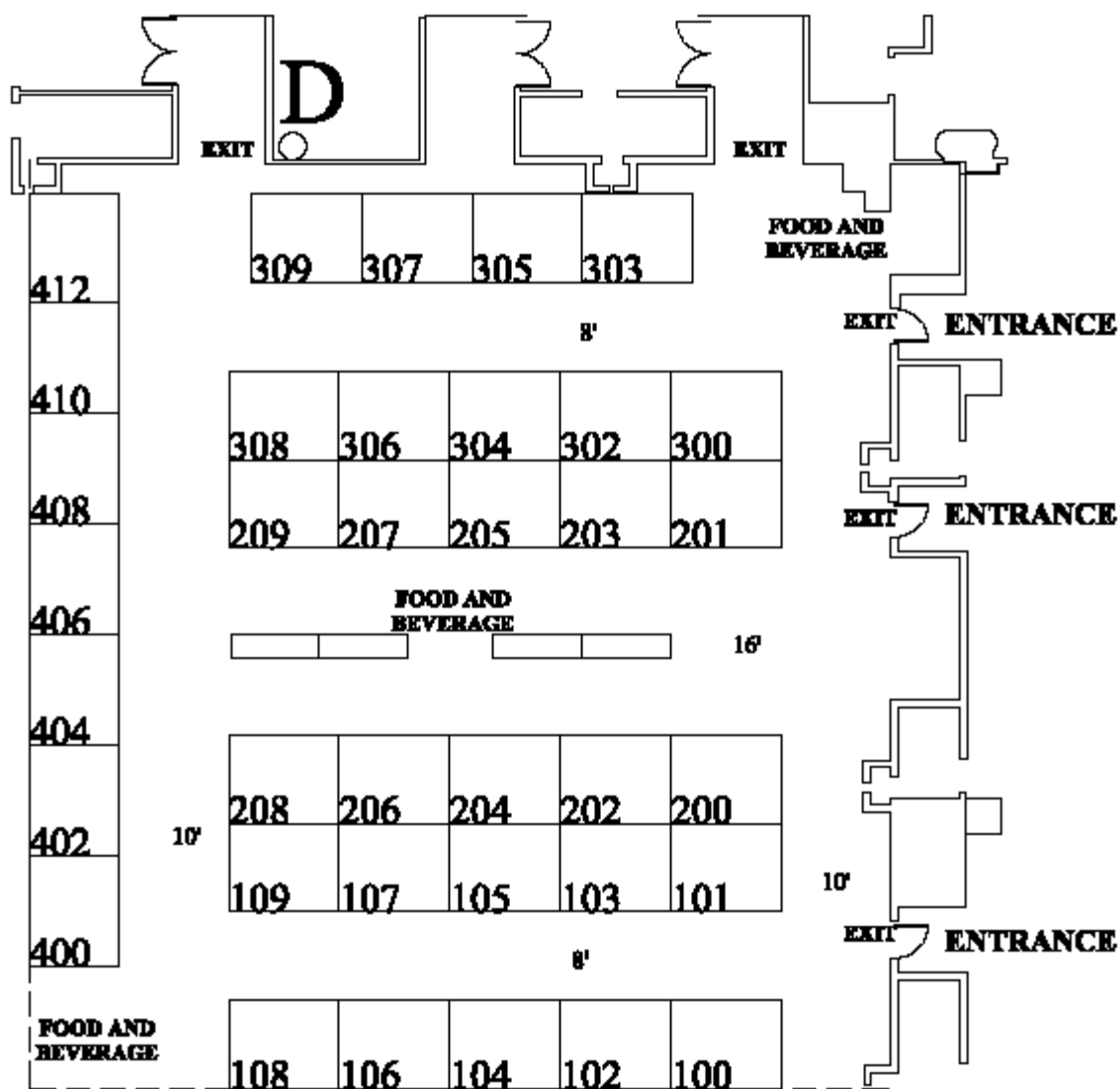

36 - 8' X 16' BOOTHS
v3

**Florida Academy of Pain
Medicine**
July 27 - 29, 2007
Sun Ballroom D
Gaylord Palms Resort



Florida Academy of Pain Medicine

P.O. Box 330298 Atlantic Beach, FL 32233-0298 Ph: 904-270-8886 Fax: 904-246-9233

2007 Annual Meeting

July 27-29, 2007

The Gaylord Palms Resort & Convention Center

Kissimmee (Orlando) Florida

Exhibitor Agreement

Company Name:

(please print **exactly** as name should appear in program and on signage.)

Contact Name _____ Title _____

Address _____

(All additional information will be mailed to this address.)

City _____ State _____ Zip _____

Phone _____ FAX _____

E-mail Address _____ @ _____

Please indicate any competitive companies. We will try to recognize this in booth placement, but we cannot make any guarantees.

Booth Assignment: Booths will be assigned at the sole discretion of show management and will be based on the date of request and consideration of competition. With reference to the floorplan, please indicate your booth preference:

1st Choice _____

2nd Choice _____

3rd Choice _____

4th Choice _____

Booth Fee: Priority - \$1,250 Each Total Number of Booths Requested: ____ Priority ____ Standard
Standard - \$950 Each

On-Site Representatives:

1.) _____ 2.) _____

(Sending more than 2 representatives is discouraged and will result in an additional fee of \$250/representative over the limit of 2.)

Amount Enclosed: \$ _____ **Method of Payment:** Check (payable to **FAPM**)

Visa MasterCard

Card # _____ Exp. Date _____

Name on Card _____ Signature _____

RULES AND REGULATIONS

1. Contract

The following rules and regulations become binding upon acceptance of this contract between the applicant and its employees, and the Florida Academy of Pain Medicine (FAPM), the show sponsor.

2. Space Assignment

Booth locations will be assigned at the sole discretion of show management. Placement will be made based on date of reservation.

3. Booth Package Description

Booth packages include 1 8' x10' pipe-and-drape booth, 1 6' draped table, 1 chair and 1 identification sign.

Total individual exhibit floor space is limited to 8'x10' unless requested and approved in writing. No walls, partitions, signs or decorations may be erected which will interfere with the general view "down the aisle", or with other exhibits.

4. Show Move-In & Move-Out

Move-In July 27, 2007

FridayEvening*

Move-Out July 29, 2007

Sunday11 am

NOTE: No exhibitor will be allowed to break down their booth until the close of the show at 11 am on Sunday, July 29, 2007.

5. Exhibit Hours

Saturday, July 28, 2007

Exhibits Open: 7 am - 7 pm

Specific Events:

Hot Pick-Up Breakfast 7 – 8 am

Coffee Break10 – 10:30 am

Beverage Break3 – 3:30 pm

Reception.....5 – 6:30 pm

Sunday, July 29, 2007

Exhibits Open: 7:30 - 11:30 am

Specific Events:

Continental Breakfast..... 7:30 – 8 am

Coffee Break 10 – 10:30 am

Move-Out11 am

6. Unoccupied Space

FAPM reserves the right, should any rented space remain unoccupied after the first hour of the show's opening, to rent or occupy said space.

7. Payments & Refunds

The total amount for exhibit space is due upon the reserving of space and signing of the contract. In the event an exhibitor cancels a contract, FAPM must be notified in writing for refunds to be made. A cancellation fee of \$50.00 will be deducted from any refund made. No refunds will be made for cancellations within two weeks of the show.

8. Food Service

FAPM reserves the right to provide food and beverage service during certain hours in the exhibit area.

9. Noisy and Obnoxious Equipment

The operation of whistles or any objectionable devices will not be allowed. After the show opens, noisy and unsightly work will not be permitted.

10. Security

Providing security for exhibits, exhibitor property and for exhibitors themselves, as well as for their employees, agents, representatives and guests, shall be the sole responsibility of the exhibitor and of the exhibitor only.

11. Fire and Safety Regulations

All local regulations will be strictly enforced and the exhibitor assumes all responsibility for compliance with such regulations. Fire hose cabinets and fire exits must be left accessible and in full view

* Times may change slightly from this schedule. If that happens, you will be notified.

at all times. All display materials and decorations must be flameproof and subject to inspection. No flammable substances may be used or shown in booths.

12. Liability and Insurance

The hotel management and FAPM will take all reasonable precautions to avoid loss of exhibitors' property by theft or fire, but under no circumstances shall the hotel management or FAPM be responsible for such losses, and it is recommended that exhibitors cover their property with suitable insurance. In the enforcement and interpretation of these rules and regulations, the decision of the Academy is final.

13. Damage to Property

Exhibitors are liable for any damage caused to the building, floor, walls, columns, or to standard booth equipment, or to other exhibitors' property. Exhibitors must not apply paint, lacquer, adhesive or any other coating to building, columns, floors or to standard booth equipment.

14. Public Policy

Exhibitors are charged with knowledge of all ordinances and regulations pertaining to taxes, health, fire prevention, customs and public safety while participating in this show. Compliance with such laws is mandatory for exhibitors and the responsibility of the exhibitor.

15. Eligible Exhibits & Restrictions

FAPM reserves the right to determine the eligibility of any company or products for inclusion in the show and reserves the right to reject, evict or prohibit any exhibit, in whole or in part, or any exhibitor or his representatives, with or without giving cause. FAPM reserves the right to deny the exhibition of inappropriate items and products. Drugs, chemicals or other therapeutic agents listed in AMA's *New and Non-Official Remedies, National Formulator or U.S. Pharmacopoeia* may be displayed. Proprietary drugs, mixtures and special formulas may be displayed if documentary evidence of their acceptance by ethical medical organizations is on file with FAPM headquarters. New, unlisted and/or initial display items must be submitted for clearance prior to opening of the Meeting. Clinical and laboratory tests and evaluation on such items must be submitted at least one month prior to the opening date of the show. The same restrictions apply to medical journal advertisements or other displayed publications and all promotional literature.

16. Exhibit Floor Access

FAPM reserves the right to limit access to the exhibit floor to anyone during times the show is not officially open.

17. Use of Booth Space

Exhibitors shall reflect their company's highest standards of professionalism while maintaining their booths during the show hours. No exhibitor shall assign, sublet or share booth space without the permission of the Academy.

18. Exhibition Sales Policy

Exhibitors may not accept payments in cash or checks or deliver merchandise in the exhibit hall.

19. Irregular Canvassing & Advertising Distribution

Solicitation of business or meetings in the interest of business except that of exhibiting firms is prohibited. Exhibitors are urged to report to FAPM any violations of this rule. Canvassing by exhibitors outside of their booths is also forbidden, except by hosts of specially-hosted events.